

Power Supply



ICL-SWPU-150W-24V

CONSTANT VOLTAGE POWER SUPPLY - NON-DIMMING

Introducing our cutting-edge 24V LED drivers, designed to redefine lighting solutions. With an IP67 rating, they are built to withstand the toughest conditions, ensuring durability and longevity. Our drivers offer DALI compatibility, enabling precise control and customisation of your lighting environment. Featuring push-to-dim and on-off functionalities, they cater to diverse lighting needs. With an astonishing 100,000 hour lifespan, these drivers guarantee lasting performance, while their flicker-free technology ensures a soothing and eye-friendly illumination experience. Elevate your lighting projects with reliability, versatility and quality - choose our 24V LED drivers for a brighter and sustainable future.

Watts:	150W
IP Rating:	IP67
Voltage:	24V DC
Input:	120-240V 50/60Hz, 0.75A Max
Output:	24V : 0A (min) - 2.5A (max)
Dimensions:	188mm x 67.5mm x 33.5mm (including end caps)
Operating Temperature:	-40°C to +90°C
Storage Temperature:	-40°C to +85°C
Great Surge Immunity:	10kV
Net Weight:	800g
Life:	100,000 hours @ Tc ≥ 75°C
Warranty:	7 years
Input Voltage:	90 ~ 305 V
Input Frequency:	47~ 63Hz
Power Factor:	>0.9 @ 60-100% load, refer to PF vs load curve
THD:	<15% @ 60-100% load, refer to THD vs load curve
Input Current:	1.4A max @ 120 Vac & Full-Load 0.75A max @ 220 Vac & Full-Load
Leakage Current:	1mA max @ 277 Vac 60Hz, UL8750, 0.75mA max @ 220 Vac 50Hz, IEC61347-1
Input Under Voltage:	Shut down and auto-restart
Surge Protection:	Line to line 6kV, line to ground 10kV, IEC 61000-4-5
Voltage Accuracy:	±3% Vo
Setup Time:	1.2 seconds max
Overshoot:	10% Vo, max
Output Over Current:	120% Io, typ.
Short Circuit:	Auto Recovery. The output recovers when short is removed

ICL-SWPU-150W-24V

Over Temperature	Turn off output when $T_c \geq 105 \pm 10^\circ\text{C}$ Auto recovery when $T_c \leq 70 \pm 10^\circ\text{C}$
MTBF	$\geq 320,000$ @ $T_c \geq 75^\circ\text{C}$ (MIL - HDBK - 217F)
Case Temperature	90°C max
UL Class:	P, ENEC/CB/CCC SELV Output
Safety:	According to EN 61147-1, 61347-2-3, 61347-2-13, 62384
Class II:	Available
Input Over Voltage Protection:	Optional
IEC 61347-1	Lamp control gear Part 1 - general safety requirements
IEC 61437-2-13	Lamp control gear part 2-13 - particular requirement for d.c or a.c supplied electronic control gear for LED modules
IEC 55015	Conducted emission test & radiated emission test
IEC 61000-3-2	Harmonic current emissions - Class C
IEC 61000-3-3	Voltage fluctuations & flicker
IEC 61000-4-2	Electrostatic discharge (ESD) : 8kV air discharge, 4 kV contact discharge
IEC 61000-4-3	Radio frequencyelectromagnetic field susceptibility (RS)
IEC 61000-4-4	Electrical fast transient (EFT)
IEC 61000-4-5	Surge immunity test
IEC 61000-4-6	Conducted radio frequency disturbances test (CS)
IEC 61000-4-8	Power frequency magnetic field test
IEC 61000-4-11	Voltage dips
IEC 61547	Electromagnetic immunit requirements applies to lighting equipment

Lifetime vs. Case Temperature

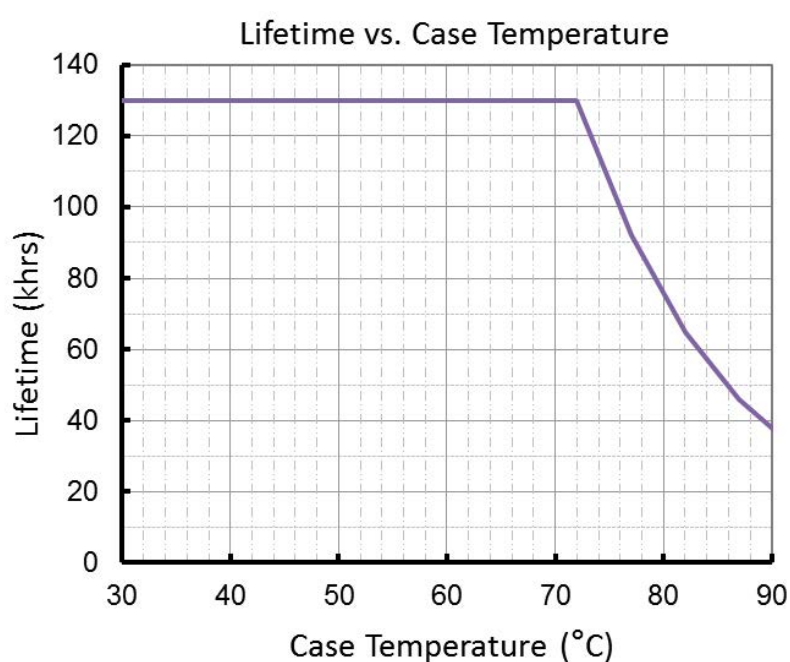

End of Life: Maximum Failure Rate = 10%

ICL-SWPU-150W-24V

Power Factor vs. Load

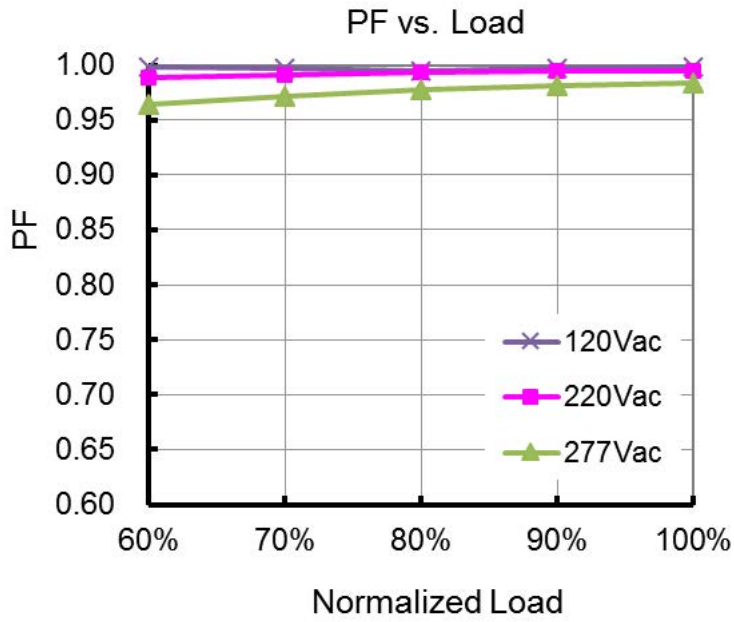

THD vs. Load

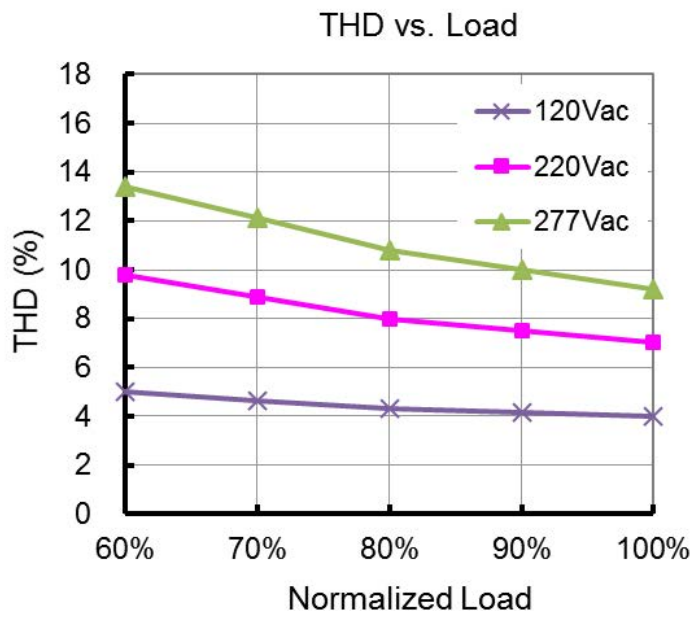

ICL-SWPU-150W-24V

Efficiency vs. Output Current

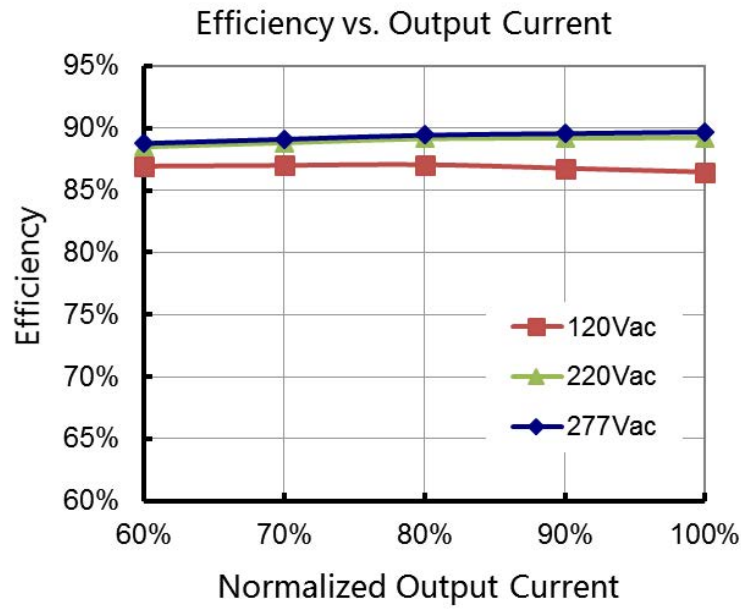

Inrush Current

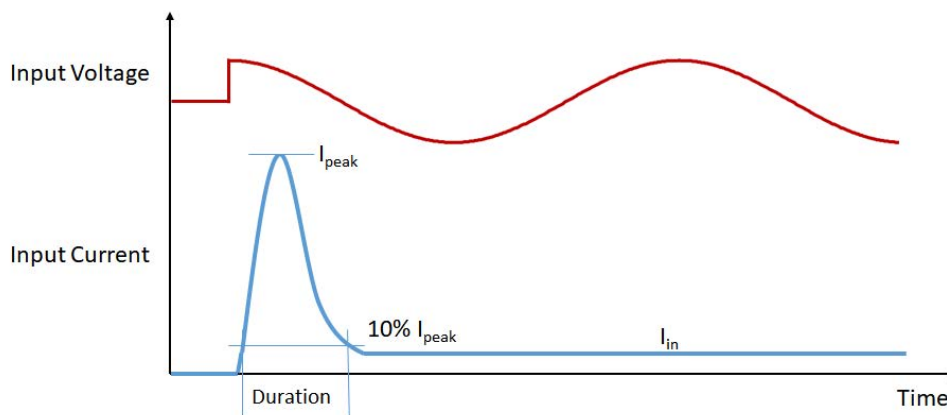

Input Voltage 120Vac:	I _{peak} : 37.2A, Duration: 824us
Input Voltage 220Vac:	I _{peak} : 66.8A, Duration: 824us
Input Voltage 277Vac:	I _{peak} : 90A, Duration: 760us

ICL-SWPU-150W-24V

Tc Point

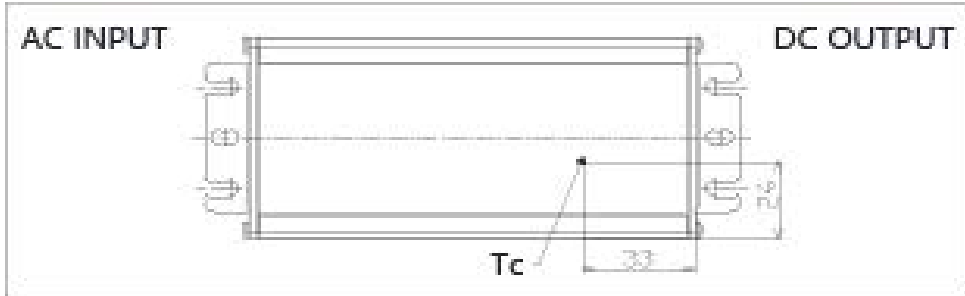

Wiring Diagram

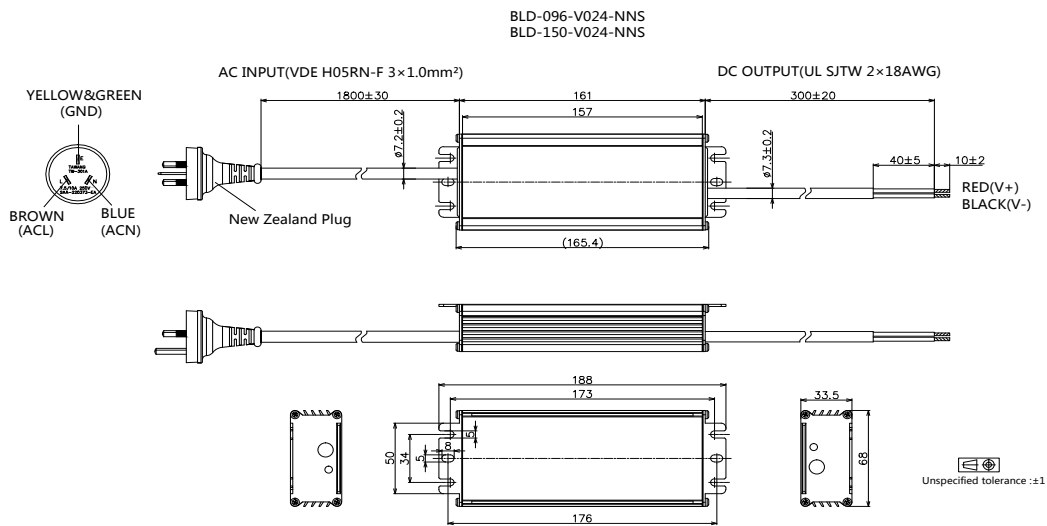

CAUTION:
Risk of electric shock

Industrial Commercial
Lighting is a New Zealand
owned and operated
lighting solutions company
based in the South Island

We provide industrial, commercial,
architectural, sports, design and
consulting lighting services.

Contact us for more information, or
to discuss how we can assist you with
a tailored lighting solution.

Phone **03 385 2291**
Email **contact@iclighting.co.nz**

www.iclighting.co.nz

